



DIRECT-ACTIVATED PRESSURE REDUCING VALVE

- ▶ The gate is designed for opening status, which will not influence the water supply function under unstable inlet pressure condition.
- ▶ When the outlet pressure responds directly to the pressure control chamber and adjusts the setting pressure, it responds quickly and adjusts the pressure accurately.



- ▶ Pressure Adjusting Range : 1~5 kgf/cm²
4~9 kgf/cm²
(special order is needed for other range)
- ▶ Valve Body Testing Pressure : 21 kgf/cm²
- ▶ Maximum Applied Pressure : 12 kgf/cm²
- ▶ Pressure needed from fully-closed gate to fully-opened gate : 1 kgf/cm² (1 kgf/cm²=14.2 psi)
- ▶ Applied Temperature : -15~80°C
- ▶ Applied Condition : Fluid & Air

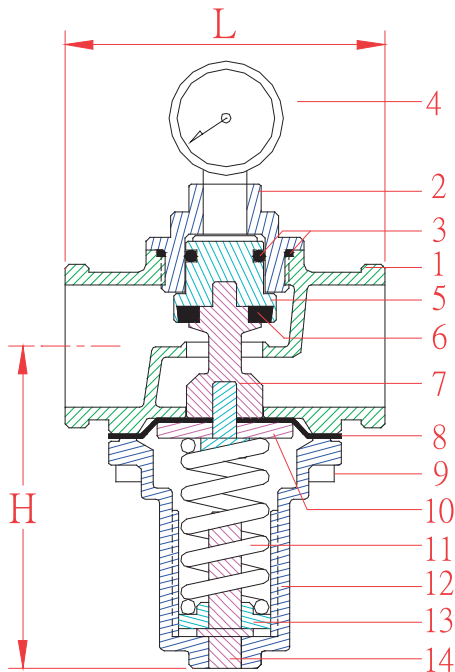

No	Part Name	Material	
1	Body	Bronze	SS304
2	Upper Cover	Bronze	SS304
3	O-ring	NBR	NBR
4	Gauge	Iron	SS304
5	Piston	Brass	SS304
6	Sealing	NBR	NBR
7	Shaft	Brass	SS304
8	Diaphragm	NBR	
9	Fixed Bolt	SS304	
10	Diaphragm Washer	SS304	
11	Spring	Spring Steel	
12	Spring Cover	Polyamide 66	
13	Spring Washer	Electroplated Iron	
14	Adjusting Bolt	Brass	

(Thread End)

Item No	Size	H(mm)	L(mm)	Weight(kg)	CV
RDT-15	1/2"	70	60	0.4	2.2
RDT-20	3/4"	70	70	0.5	3.8
RDT-25	1"	80	80	0.8	6.4
RDT-32	1.25"	85	90	1.5	10.3
RDT-40	1.5"	110	110	2.5	12.6
RDT-50	2"	115	115	3	17.2

$$CV = \frac{Q}{\sqrt{\Delta P/S}}$$

Q=GPM (gallon/min)

$\Delta P = P1 - P2$ (p.s.i)

P1=Inlet absolute pressure

P2=Outlet absolute pressure

S=Fluid Density (Water=1)

1 gallon=3.785 liter

